

核内レセプターによる薬物代謝酵素の 発現調節機構に関する研究

千葉大学大学院薬学研究院
薬物学研究室

小林カオル

Induction of drug metabolizing enzymes

Effects on drug therapy and toxicity

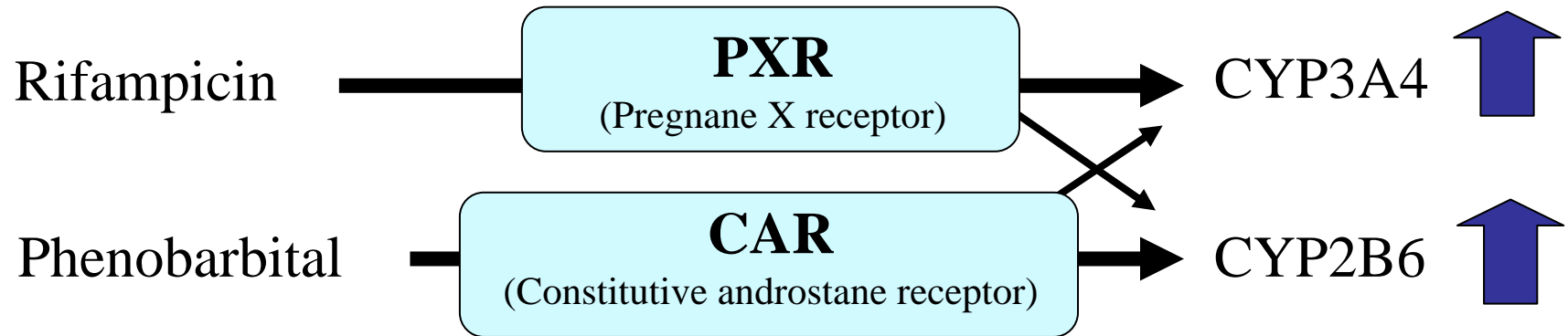

CYP2A6, CYP2C8, CYP2C9, CYP2C19, CYP3A7, UGT1A1, SULT2A1, GSTs....etc.

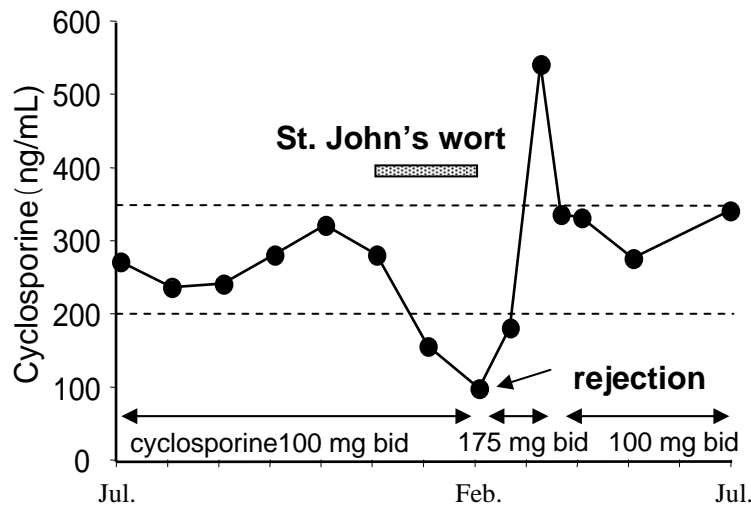

Gary et al., 2000

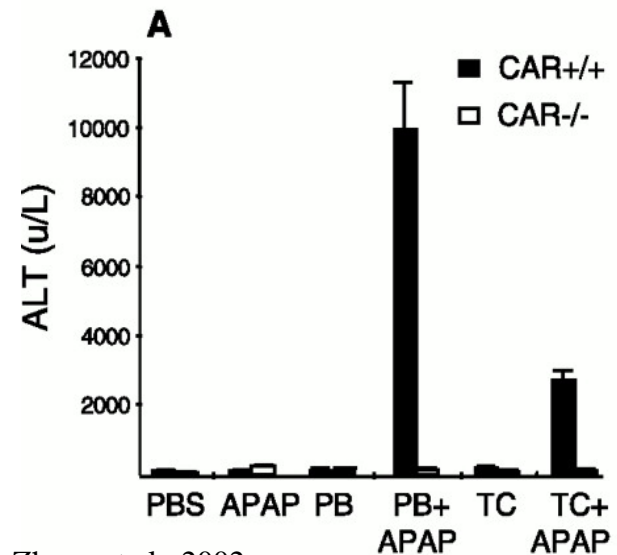

Zhang et al., 2002

Intracellular localization of CAR

Hepatocytes

HepG2 cells

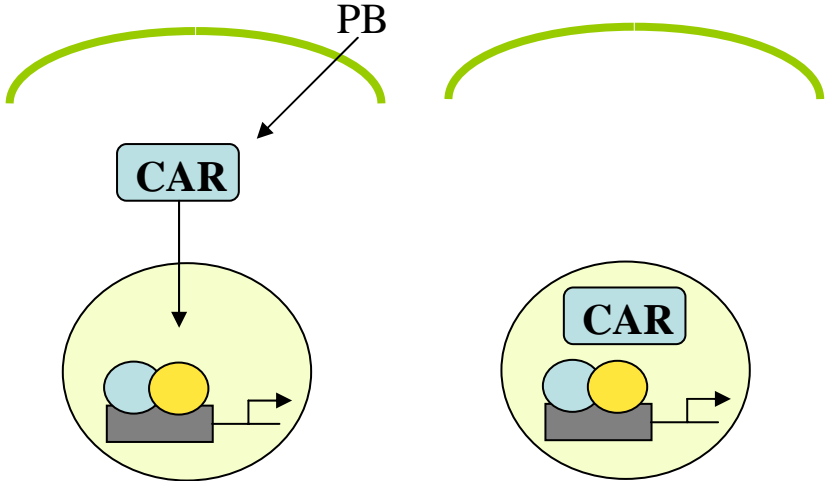

Exogenous CAR protein in HepG2 cells

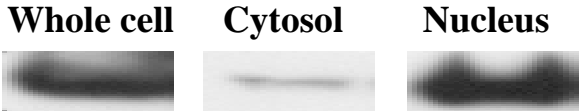

Cytoplasmic accumulation of CAR by CCRP

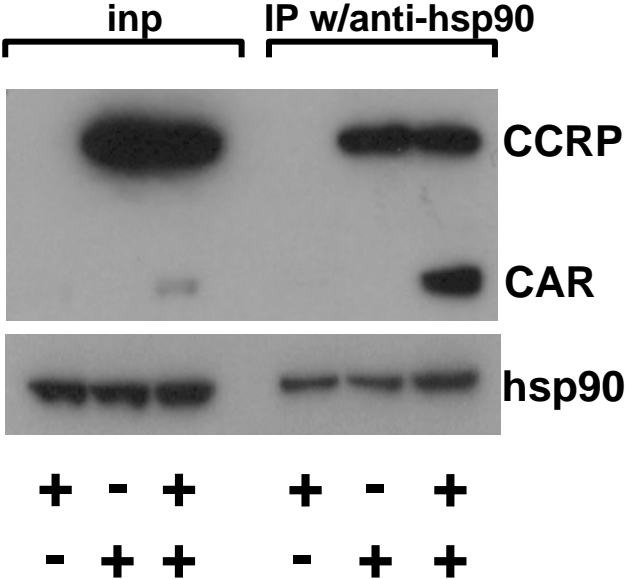
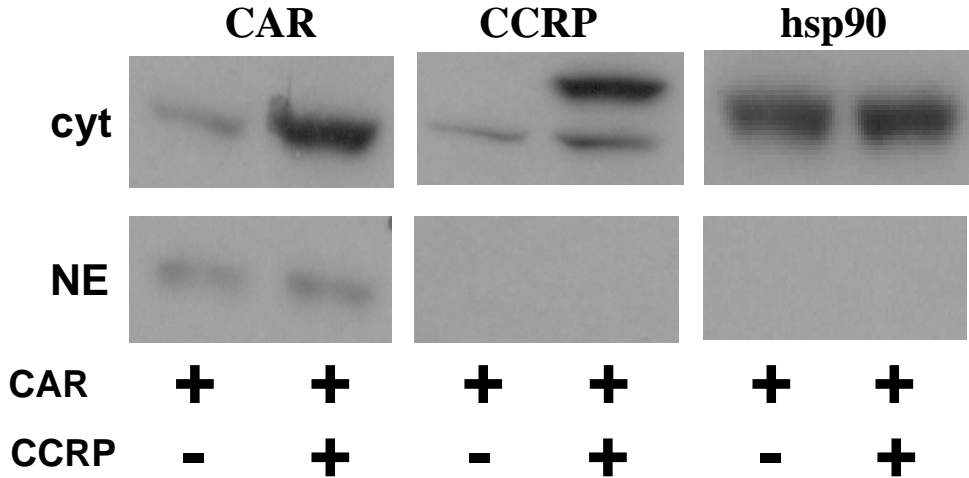

In vivo expression of fluorescent protein-tagged CAR and CCRP

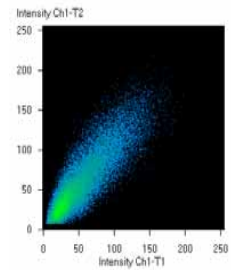
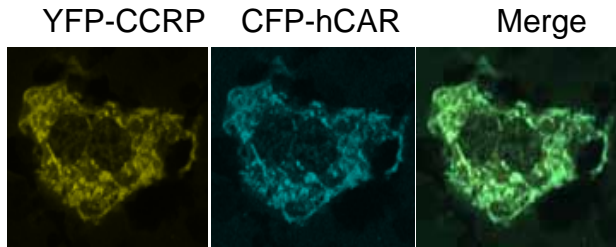
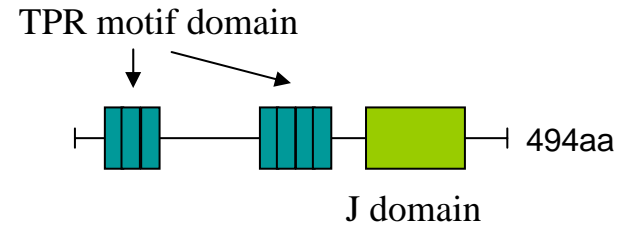
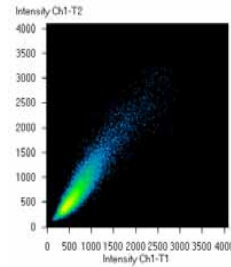
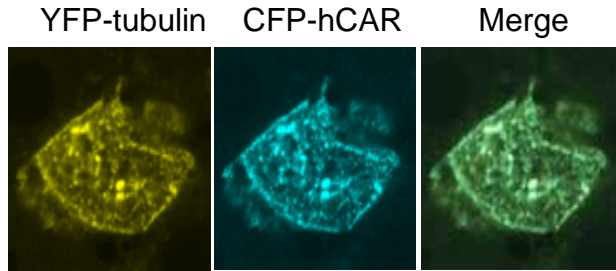

Domains of CCRP

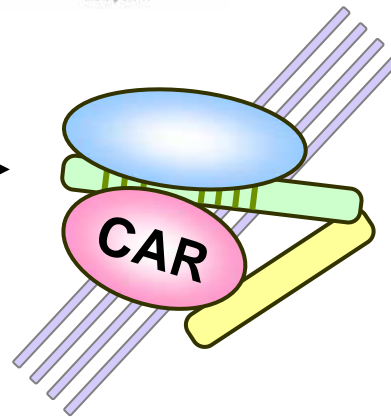
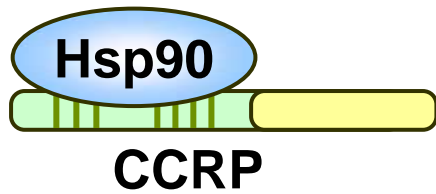

PB

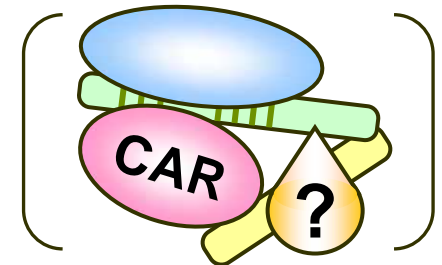

Identification of statins as human CAR activators

Reporter gene assay

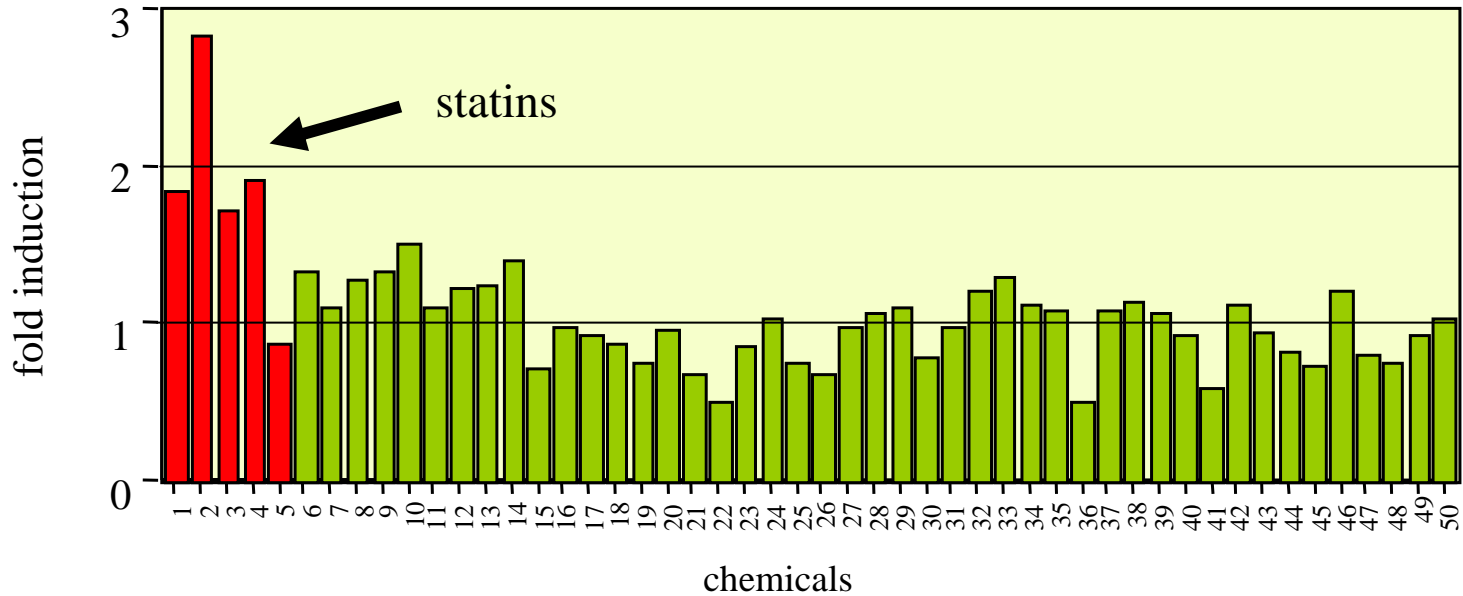

CYP2B6 mRNA

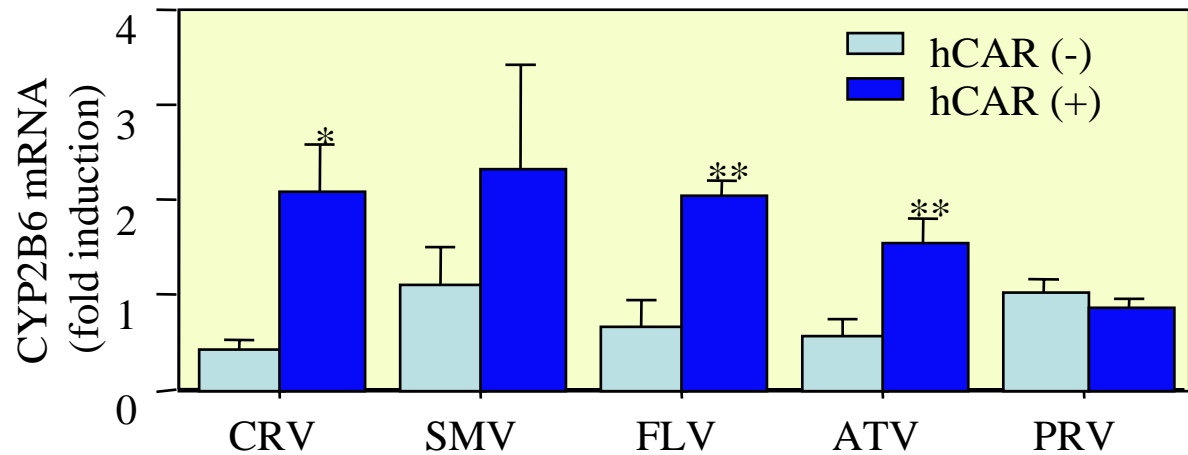

Effects of barbiturates on hPXR activation

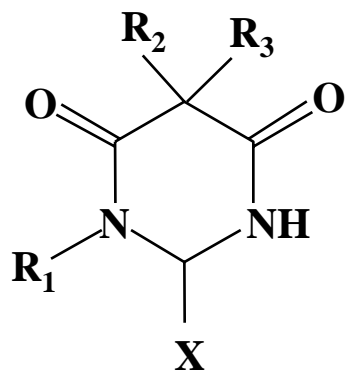
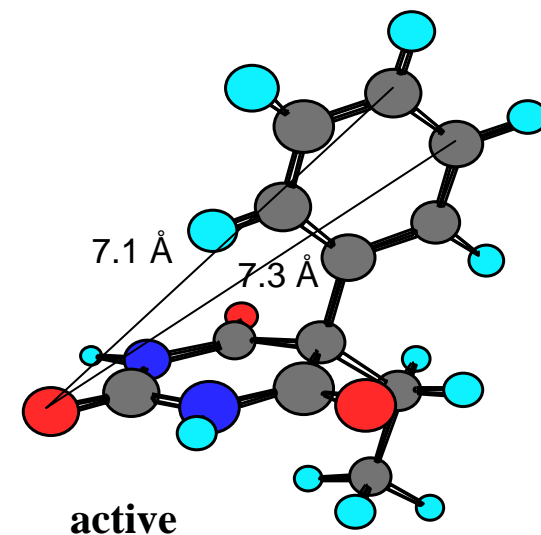
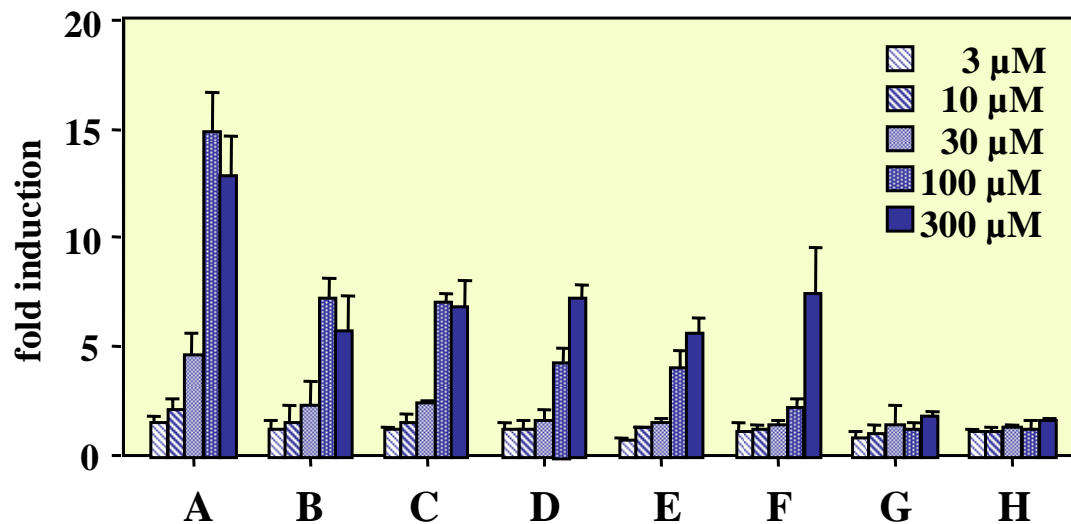

Compound	X	R ₁	R ₂	R ₃
A Mephobarbital	O	CH ₃	C ₂ H ₅	C ₆ H ₅
B Pentobarbital	O	H	C ₂ H ₅	C ₅ H ₁₁
C Hexobarbital	OH	CH ₃	CH ₃	C ₆ H ₉
D Cyclobarbital	O	H	C ₂ H ₅	C ₆ H ₉
E Amobarbital	O	H	C ₂ H ₅	C ₅ H ₁₁
F Phenobarbital	O	H	C ₂ H ₅	C ₆ H ₅
G Barbital	O	H	C ₂ H ₅	C ₂ H ₅
H Primidone	H	H	C ₂ H ₅	C ₆ H ₅

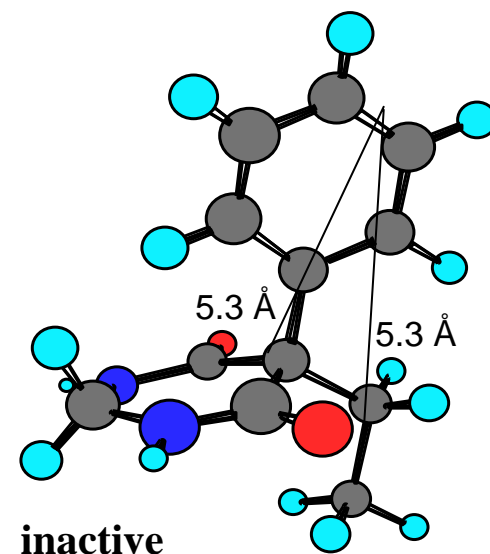

Effects of amino acid mutation on the PXR activation

Amino acid sequence of PXR-LBD

141 QGLTEEQRMMIREL
 MDAQMKTFTDTFSH
 FKNFRLPGVLSGCG
 ELPESLQAPSREEA
 AKWSQVRKDLCSLK
 VSLQLRGEDGSVWN
 YKPPADSGGKEIFS
 LLPHMADMSTYMFK
 GIISFAKVISYFRD
 LPIEDQISLLKGAA
 FELCQLRFNTVFNA
 ETGTWECGRLSYCL
 EDTAGGFQQLLEP
 MLKFHYMLKKLQLH
 EEEYVLMQAISLFS
 PDRPGVLQHRVVDQ
 LQEQFAITLKSIE
 CNRPQPAHRFLFLK
 IMAMLTELRSINAQ
 HTQRLLRIQDIHPF
 ATPLMQELFGITGS 434

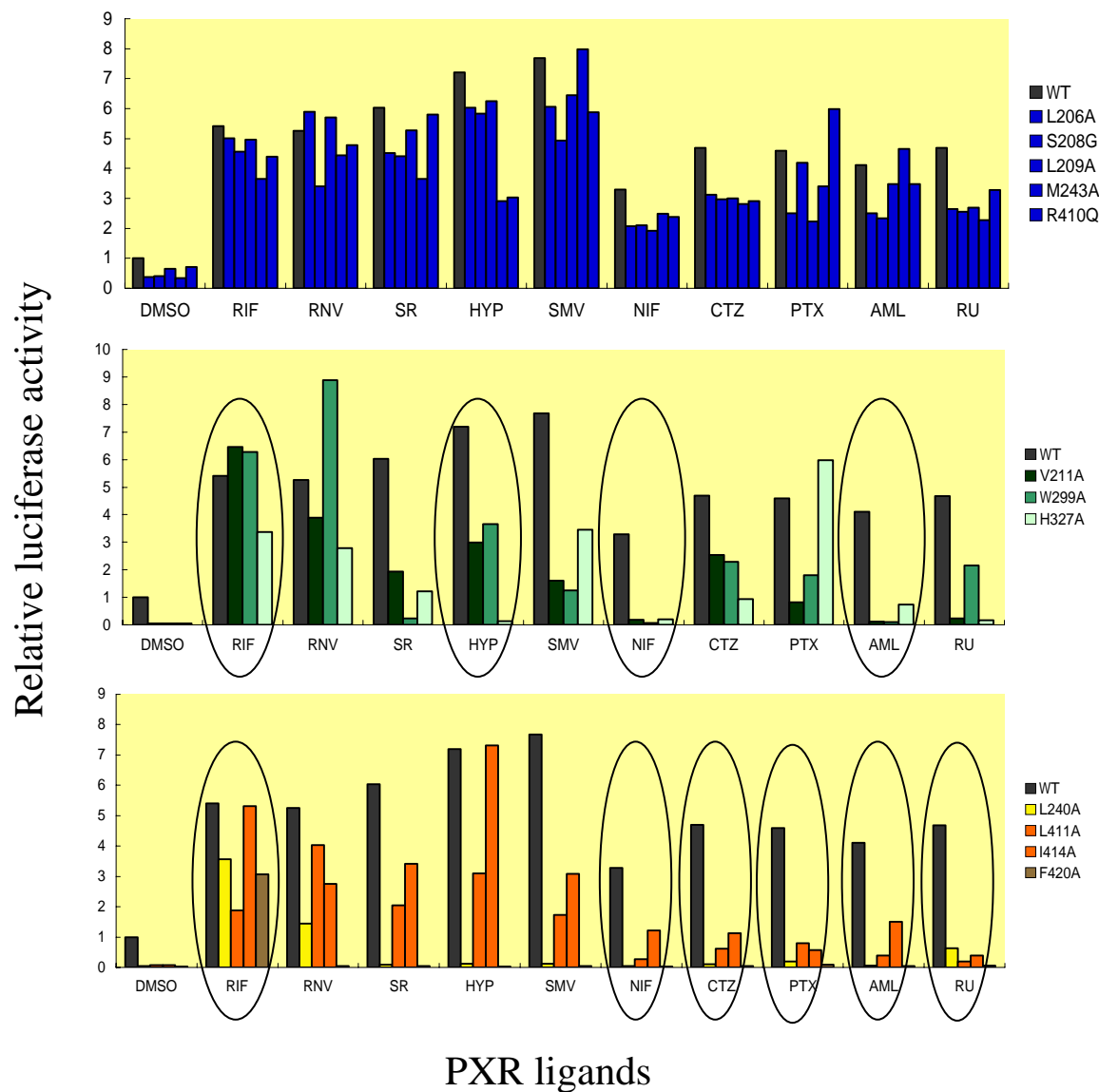

Proposed interaction between PXR and ligands

clotrimazole

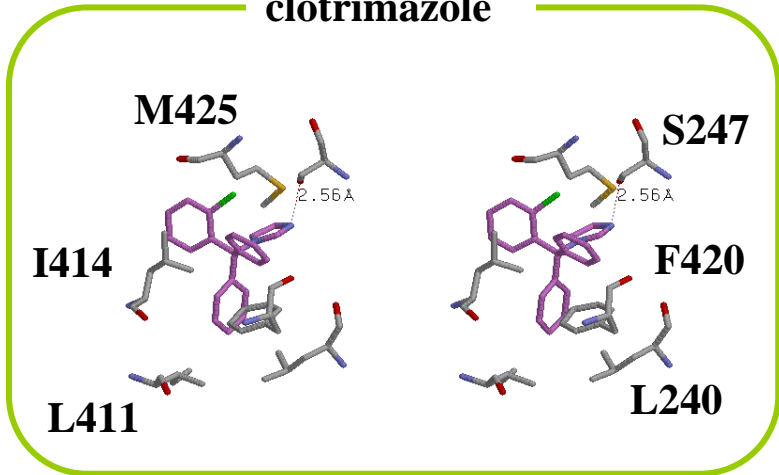

nifedipine

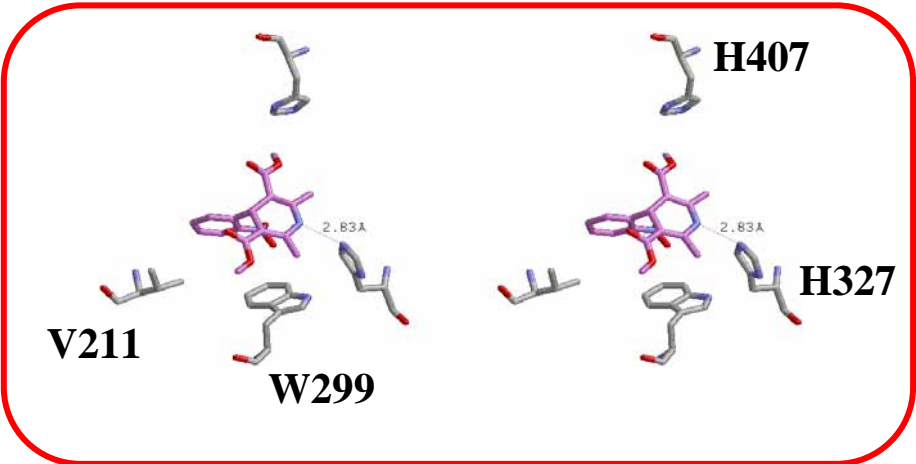
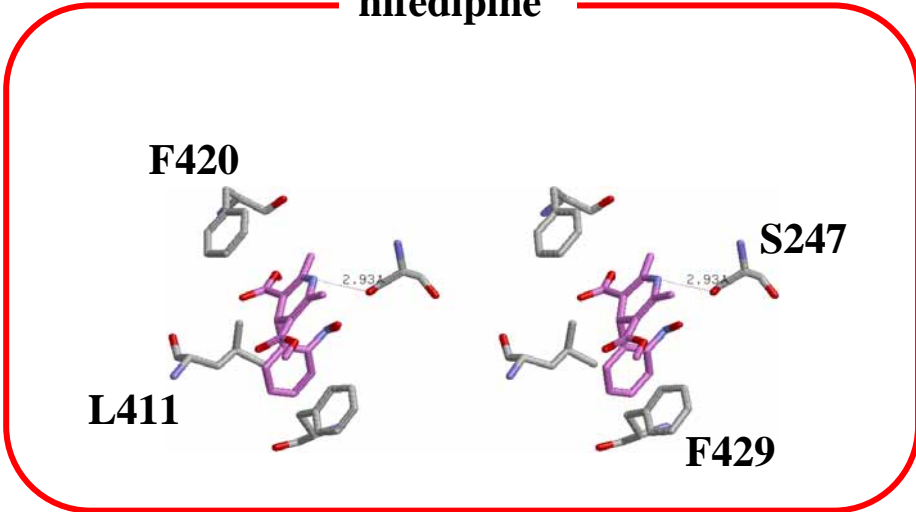

Involvement of HNF4 α in transcriptional regulation of human *PXR* gene

Mutation assay

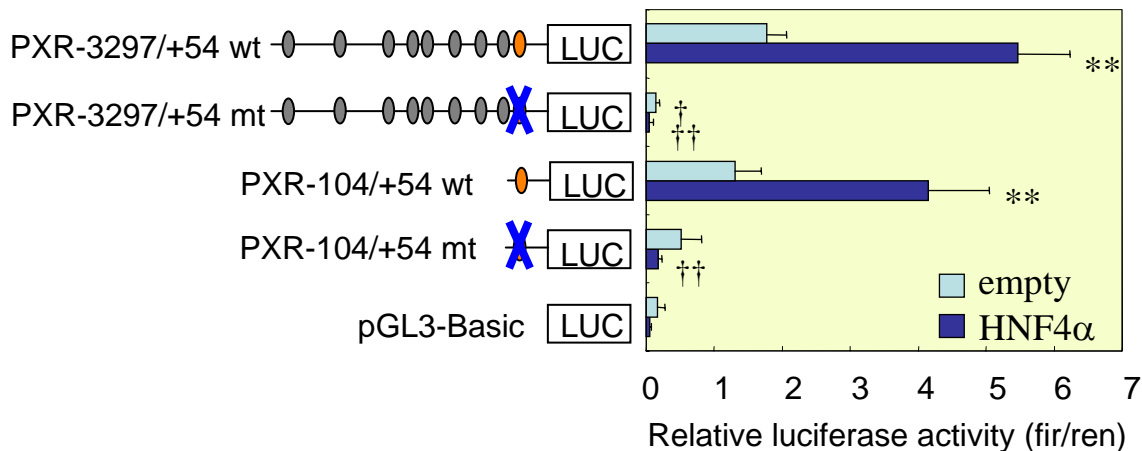

Human -88 TGGACTTGGGACT -76
 |||||
 Mouse -44 TGCTGGACTTGGGACTTGG -26

ChIP assay

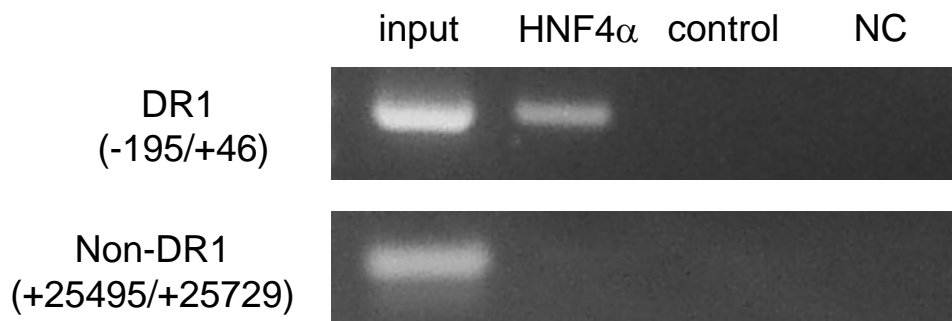

RNAi for HNF4 α

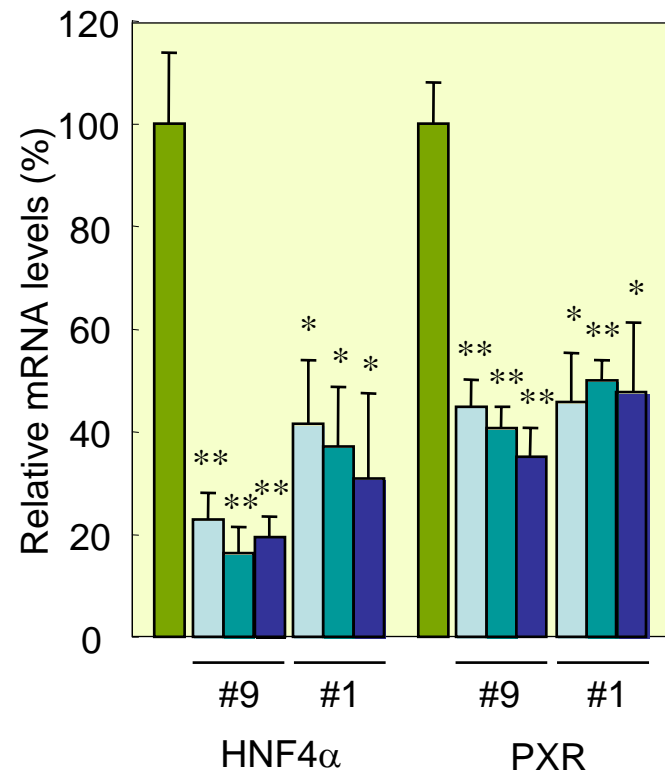

Involvement of HNF4 α in the different expression levels between *CYP2C9* and *CYP2C19* in the human liver

Mutation assay

DR1
A B

CYP2C9

CYP2C19

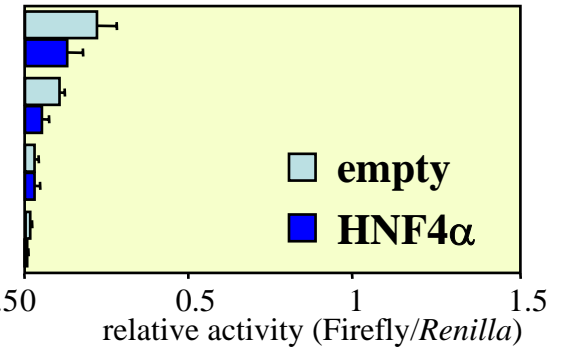
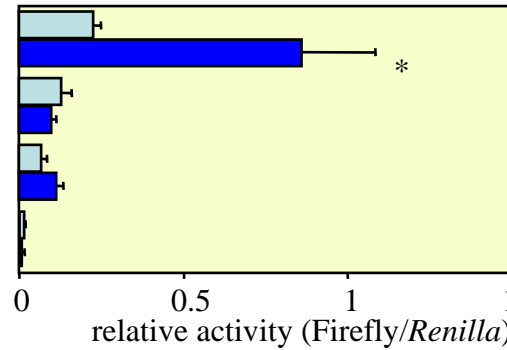
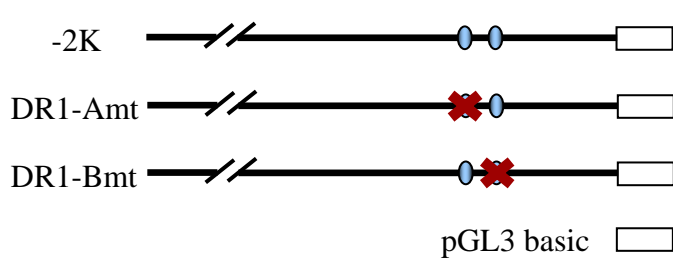

ChIP assay

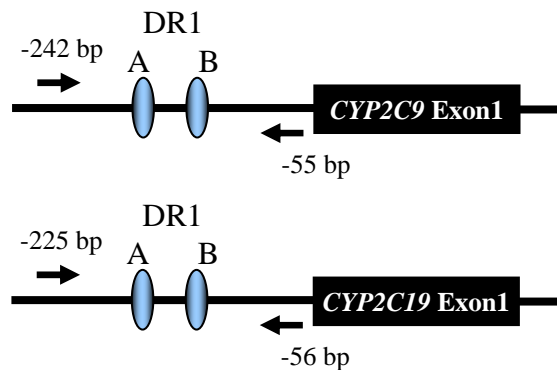

CYP2C9

CYP2C19

Input HNF4 α Cont NC

Input HNF4 α Cont NC

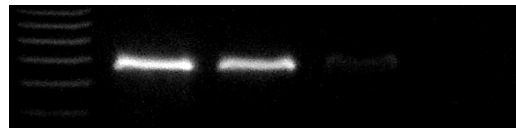

Effects of HNF4 α and COUP-TFII on the promoter activity of *CYP2C9* gene

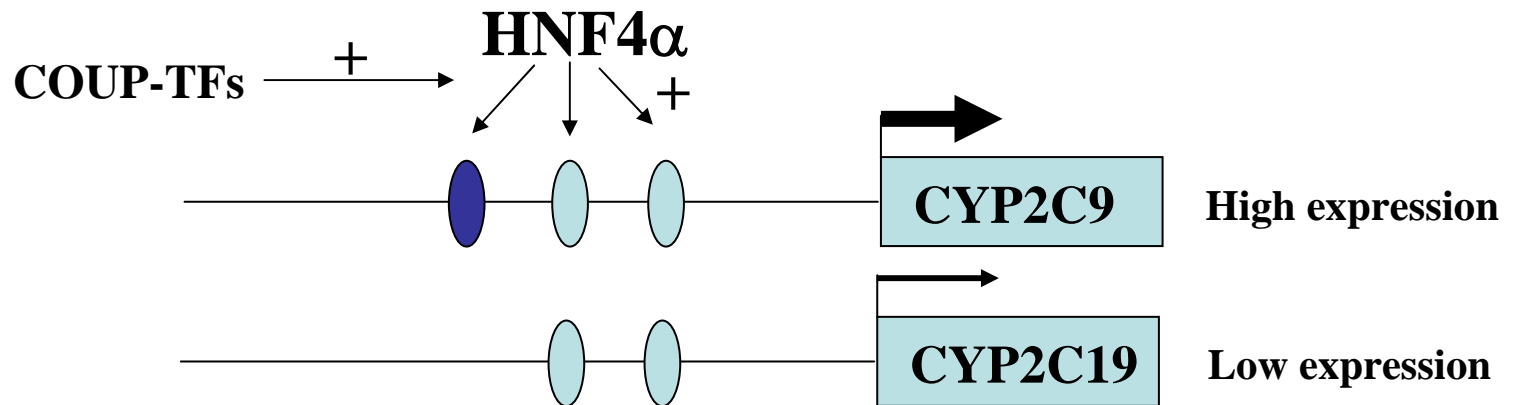
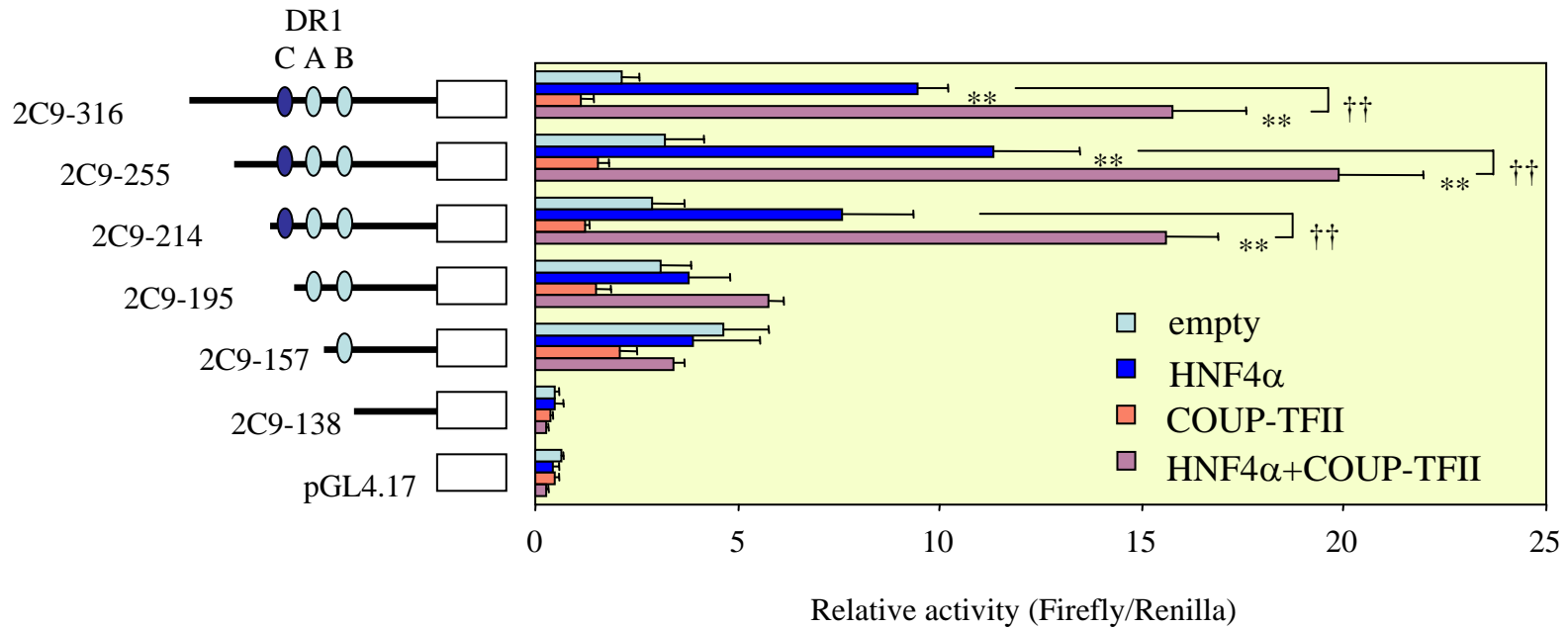

Outline of our studies

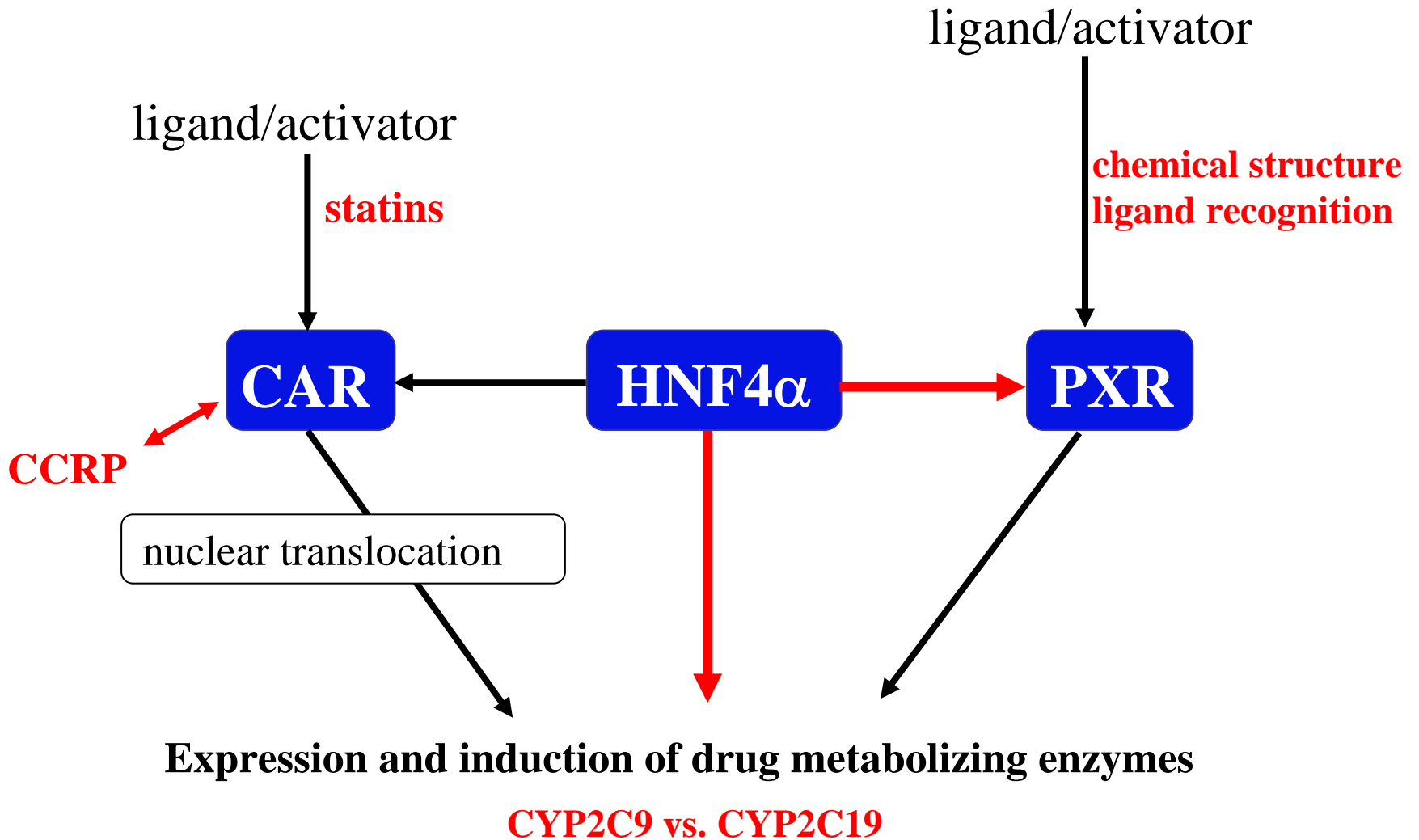

Acknowledgements

千葉 寛 教授
細川正清 教授(現 千葉科学大学)
降幡知巳 助教
森本かおり 博士(現 高崎健康福祉大学)
清水俊之 博士
樋口智明 修士
高間香織 修士
山上紗絵子 修士
山中陽介 修士
川島さち代 修士
岩崎紀彦 修士
三家本雅樹 修士
齊藤公亮 修士
井上直樹 修士
平野 舞 修士

畑 晶之 博士
(現 松山大学)

Dr. Masahiko Negishi
Dr. Tatsuya Sueyoshi
Dr. Koichi Yoshinari
Dr. Kaoru Inoue
Mr. Rick Moore

千葉大学大学院薬学研究院薬物学研究室



NIEHS/NIH



National Institute of Environmental Health Sciences (NIEHS) / NIH